



**tET-P2A2**  
**tET-P2C2**

**tPET-P2A2**  
**tPET-P2C2**

Tiny Ethernet Module with 2-ch DI, 2-ch DO

### Features

- Web Server for Configuration
- Cost-effective Tiny Ethernet I/O Modules
- Support Modbus TCP/UDP and MQTT Protocols
- I/O Pair Connection (Push and Pull)
- Redundant Power Inputs: PoE (IEEE 802.3af, Class 1) and DC input
- Supports Dual-watchdog
- Supports Firmware Update via Ethernet
- Supports Latched DI, 32-bit DI Counters, and Frequency Measurement
- DO Power-on Value and Safe Value



### Introduction

The **tET/tPET** series is an IP-based Ethernet I/O monitoring and control module. The module can be remotely controlled through a 10/100 M Ethernet network by using Modbus TCP protocol.

The functionality of the tET/tPET series is almost the same as the ET-7000/PET-7000 series. The module can be used to create DI to DO pair-connect through the Ethernet. Once the configuration is completed, the tET/tPET series module can poll the status of the local DI channels and then use the Modbus/TCP protocol to continuously write to a remote DO device in the background.

The tET/tPET series provides a dual-watchdog function: a CPU watchdog and a host watchdog. The CPU watchdog automatically resets the system when the built-in firmware runs abnormally. The host watchdog monitors the host controller (PC or PLC), and the module's output can switch to a predefined "Safe Value" when the host fails.

It features a powerful 32-bit ARM MCU to handle efficient network trafficking. The **tPET** series offers true IEEE 802.3af-compliant (classification, Class 1) Power over Ethernet (PoE) using a standard category 5 Ethernet cable to receive power from a PoE switch like the NS-205PSE. When there is no PoE switch on site, the tPET series accepts power input from the DC adapter.

### System Specifications

Model	tET-P2A2	tET-P2C2	tPET-P2A2	tPET-P2C2
<b>Software</b>				
Built-in Web Server	Yes			
<b>CPU Module</b>				
CPU	32-bit MCU			
Watchdog Timer	Module, Communication (Programmable)			
<b>EMS Protection</b>				
EFT (IEC 61000-4-4)	±4 kV for Power Line			
ESD (IEC 61000-4-2)	±4 kV Contact for Each Terminal, ±8 kV Air for Random Point			
<b>LED Indicators</b>				
Status	Run, Ethernet		Run, Ethernet, PoE	
<b>Ethernet</b>				
Ports	1 x RJ-45, 10/100 Base-TX			
PoE	-		Yes	
Access Control	Password and IP Filter			
Protocol	Modbus TCP, Modbus UDP, MQTT			
<b>Power</b>				
Reverse Polarity Protection	Yes			
Consumption	0.9 W		1.0 W	
Powered from PoE	-		IEEE 802.3af, Class 1	
Powered from Terminal Block	+12 ~ +48 VDC			
<b>Mechanical</b>				
Dimensions (mm)	52 x 95 x 27 (W x L x H)			
Installation	DIN-Rail Mounting			
<b>Environment</b>				
Operating Temperature	-25 ~ +75 °C			
Storage Temperature	-30 ~ +80 °C			
Humidity	10 ~ 90% RH, Non-condensing			

## I/O Specifications

Model	t(P)ET-P2A2	t(P)ET-P2C2
<b>Digital Input/Counter</b>		
Channels	2	
Type	Wet Contact	
Sink/Source (NPN/PNP)	Sink/Source	
ON Voltage Level	+10 ~ +50 VDC	
OFF Voltage Level	+4 VDC (max.)	
Max. Counts	4,294,967,295 (32-bit)	
Frequency	3.5 kHz (without filter)	
Min. Pulse Width	0.15 ms	
Isolation	3750 Vrms	
Input Impedance	10 kΩ	
Overvoltage Protection	+70 VDC	
<b>Digital Output</b>		
Channels	2	
Type	Open Collector	
Sink/Source (NPN/PNP)	Source	Sink
Load Voltage	+10 ~ +40 VDC	+5 ~ +30 VDC
Load Current	650 mA/channel	100 mA/channel
Overvoltage Protection	+48 VDC	+60 VDC
Short-circuit Protection	Yes	-
Isolation	3750 Vrms	

## Dimensions (Units: mm)

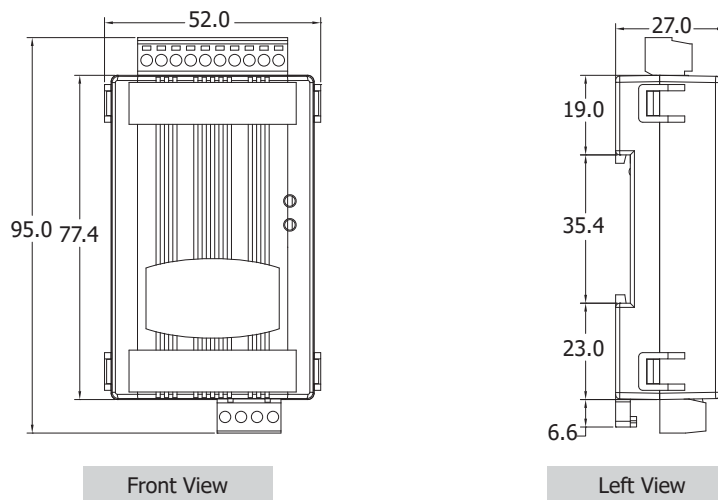

## Pin Assignments

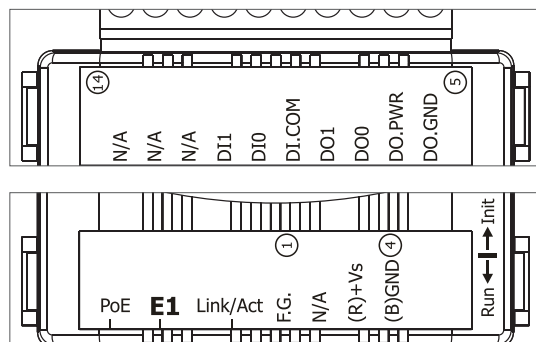

PoE: tPET-P2A2/tPET-P2C2

## Wire Connections

Digital Input	Readback as 1	Readback as 0
	+10 ~ +50 VDC	OPEN or <4 VDC
Sink		

Digital Input	Readback as 1	Readback as 0
	+10 ~ +50 VDC	OPEN or <4 VDC
Source		

Model	t(P)ET-P2A2	
Digital Output	Readback as 1	Readback as 0
	Relay ON	Relay OFF
(Source) Drive Relay		
(Source) Resistance Load		

Model	t(P)ET-P2C2	
Digital Output	Readback as 1	Readback as 0
	Relay ON	Relay OFF
(Sink) Drive Relay		
(Sink) Resistance Load		

## Ordering Information

tET-P2A2 CR	23 Tiny Ethernet Module with 2-ch DI, 2-ch DO (Source, PNP) (RoHS)
tET-P2C2 CR	Tiny Ethernet Module with 2-ch DI, 2-ch DO (Sink, NPN) (RoHS)
tPET-P2A2 CR	6 Tiny PoE Ethernet Module with 2-ch DI, 2-ch DO (Source, PNP) (RoHS)
tPET-P2C2 CR	Tiny PoE Ethernet Module with 2-ch DI, 2-ch DO (Sink, NPN) (RoHS)